

TRUMPF Additive Manufacturing for mold and die

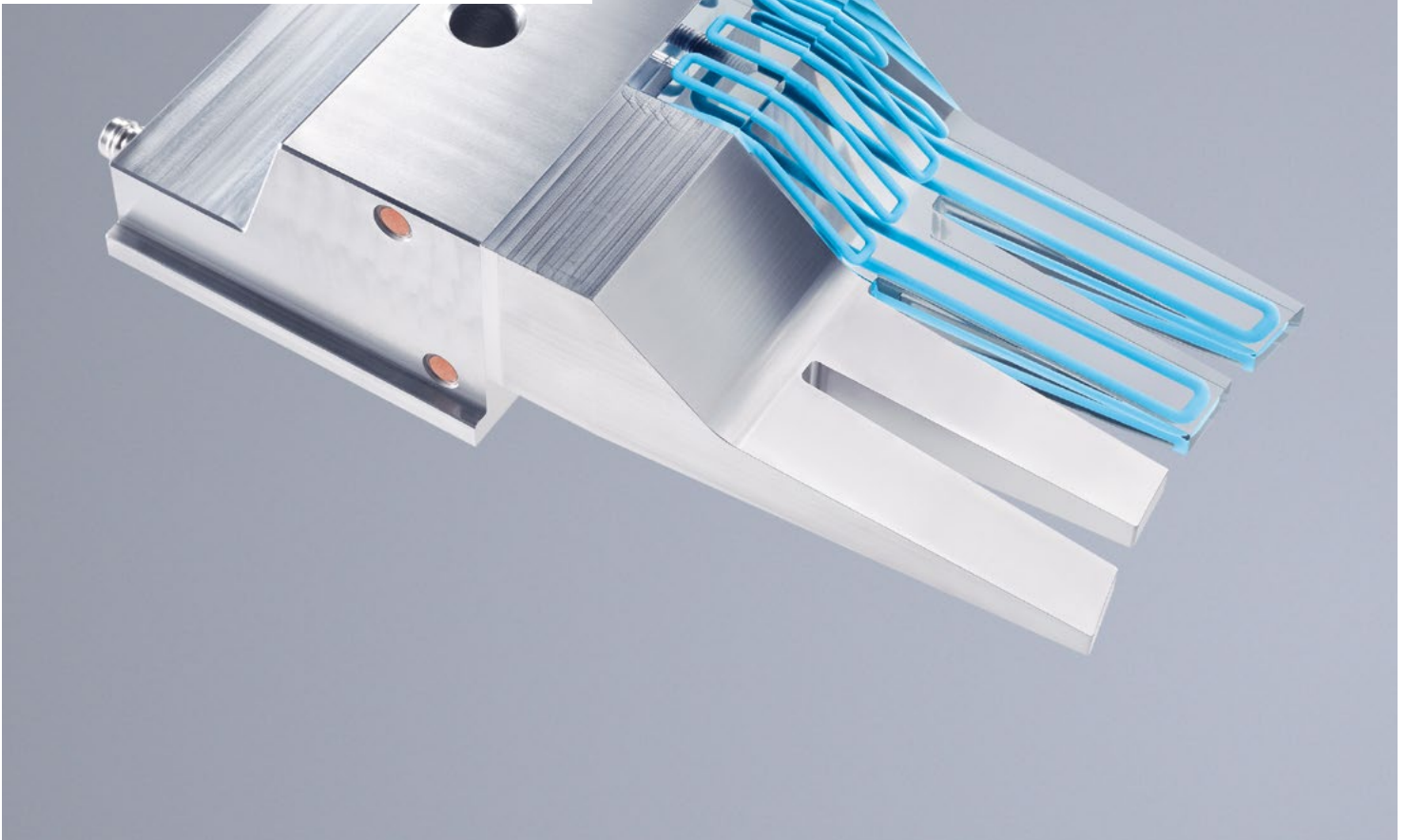

The supplier with the most tool steels from metal 3D printer for mold making

TRUMPF Additive Manufacturing machines for mold and die offer the broadest material portfolio of all machine manufacturers for the mold and die industry. Hot-forming steels H11/13 (1.2343/44), Uddeholm Dievar® or tool steels 1.2709, as well as 1.3343 – the right steel for every mold and die application.

Advantages for the mold and die industry

- **Reduction of cycle times**
in plastic injection moulding or aluminum die casting by an average of 20 to 30%.
- **Improved part quality**
 - Better surface quality
 - More detailed parts/material savings
 - Less warpage and scrap
- **Increase in tool life**
 - Increased lifetime even in die casting
 - Less machine downtime due to rework



Possible materials

Without carbon

- 1.2709
- M789
- Corrax

➤ No preheating necessary

Carbon-containing steels

- H11/H13
- Dievar®
- 1.3343

➤ 500°C preheating recommended

How does it work?

Conventional cooling

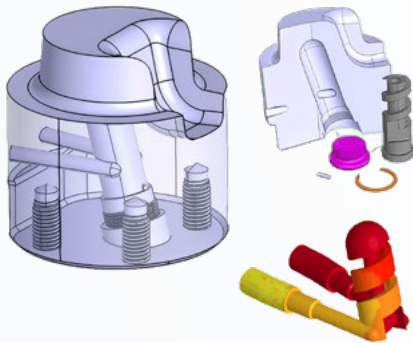

Efficient and homogeneous cooling due to near-contour/surface channels

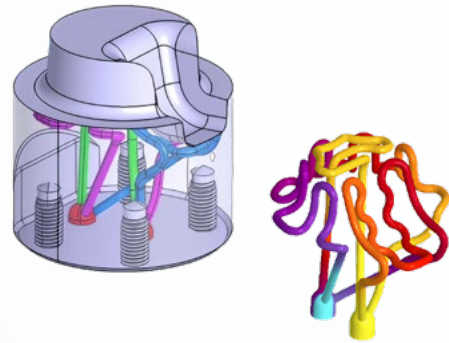

Process chain

Design (and simulation)
of the cooling channels



3D-printing of the tool
and heat treatment



Conventional machining to achieve
the final shape and surface

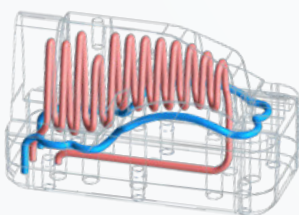

Preheating 500 °C: First time right!

Imagine being able to print larger components from tool steel H11 or Dievar® and getting instantly perfect results. No cracks, less thermally induced stress in the component and no problems from detached support structures. Not possible? It is possible using the TruPrint 5000 with 500 °C preheating.

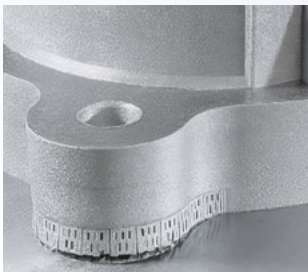

Component printed **without** 500 °C preheating.

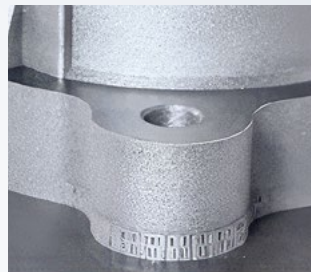

Component printed **with** 500 °C preheating.

Why 500 °C preheating?

Your benefits: With our TruPrint 5000 and 500 °C preheating of the substrate plate, you always have control over the temperatures in the process chamber. Homogeneous heat distribution, which specifically prevents stress in the component and thus the formation of cracks in tool steels containing carbon, reliably achieves optimum printing results for your application.

Example injection mould

- Material: 1.2709
- Can be produced on TruPrint 2000, 3000 or 5000
- ≥ 99.9% density
- Crack-free
- Reduction of cooling time by 28% (7.5 s)
- 35% less distortion (0.09 mm)

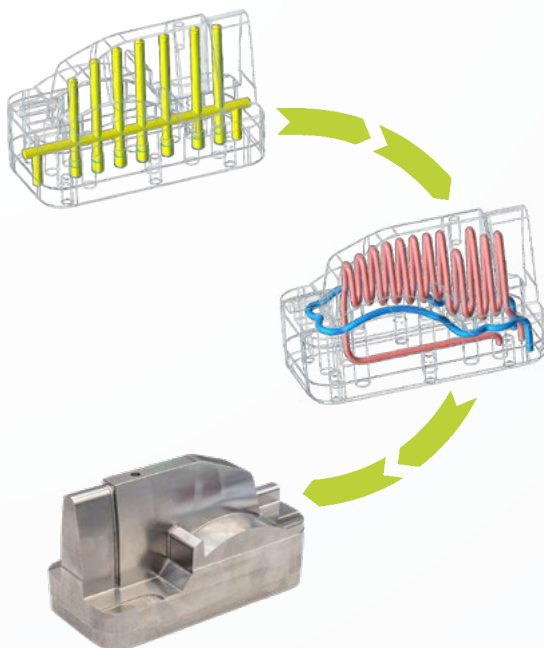

Example aluminum die casting

- Material: H11 or Dievar®
- Produced on TruPrint 5000 with 500 °C preheating
- ≥ 99.9% density
- Crack-free
- Reduction of cooling time by 30%
- Microspraying easier to implement
- Improved mold life

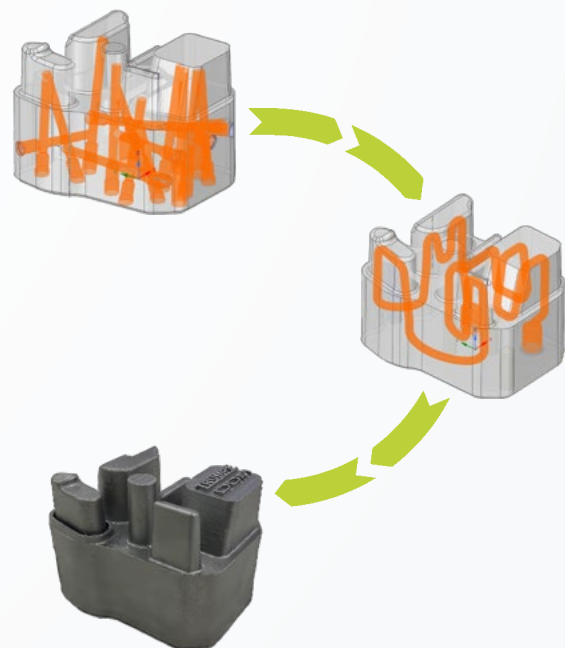

Our products for your Additive Manufacturing



TruPrint 1000 $\varnothing 100 \times H 100$ mm

3D printing in premium quality:
Highly productive and compact

- Highest build rates and machine run time
- Superior part and surface quality
- Ergonomic contact-free powder handling
- Process flexibility and advanced monitoring
- Best fit for dental applications
- Lower part costs due to preform, Multiplate and hybrid, digital chain

TruPrint 5000 $\varnothing 300 \times H 400$ mm

Highly productive and semi-automated
3D printing system

- Full-field multilaser 3 \times 500 W with Automatic Multilaser Alignment for high part quality
- Preheating up to 500 °C (optional)
- Inert, closed powder cycle
- External part and powder management compatible for TruPrint 3000 and TruPrint 5000
- **NEW:** Preform option for hybrid manufacturing

TruPrint 2000 $L 202 \times W 202 \times H 200$ mm

Productivity squared

„World Premiere“

- Process flexibility due to adjustable beam diameter (55/80 μ m)
- Highly productive due to full-field multilaser option 2 \times 300 W (opt. 2 \times 500 W)
- Low part costs due to perfectly tailored machine concept
- Highest quality standards through Melt Pool Monitoring
- Inert, closed powder cycle

TruPrint 5000 Green Edition

$\varnothing 300 \times H 400$ mm

3D printing of copper and copper alloys

- Unique combination of green laser and additive manufacturing system
- Highest quality and productivity through green laser with wavelength of 515 nm
- Outstanding thermal properties and electrical conductivities

TruPrint 3000 $\varnothing 300 \times H 400$ mm

Flexible solution for industrial 3D printing

- Maximum productivity through full-field multilaser 2 \times 500 W
- High process reliability due to newly developed gas flux
- Flexible production setup
- Ensuring high quality standards with Automatic Multilaser Alignment
- Inert, closed powder cycle
- **NEW:** 3D printing of aluminum with 2 \times 700 W

You can find more information online at:
www.trumpf.com/s/additivemanufacturing
Or contact our experts directly:
additive.manufacturing@trumpf.com

You are interested in seeing the machines or in having a virtual demonstration of our 3D printers? Make an appointment now at:
www.trumpf.info/am-showroom